

Office Building For Lease

*15835 Pomerado Road
Poway, CA*



Medical/Dental Offices Available

Property Information

- Great Location with Convenient Freeway Access
 - Built out Medical/Dental Suites
- Just up the street from Pomerado Hospital and Arch Health Partners
 - Surrounded by high income households
- Close to Rancho Bernardo High School, with easy access to nearby neighborhood and regional shopping centers
 - Located on a signalized intersection

Contact Broker for additional information.



Available

\$2.75 MG

Suite 102 - 1,047 sf

Suite 402 - 1,670 sf

Suite 403 - 1,467 sf

Floor Plan - Suite 102

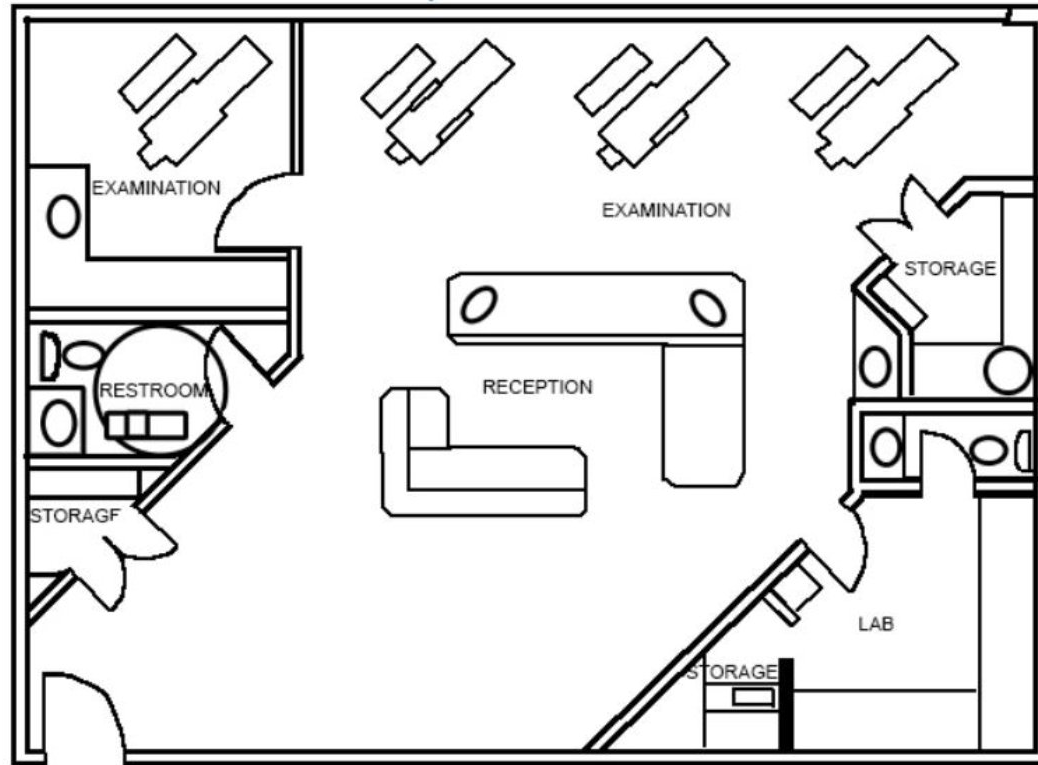

Suite 102

1,047 SF

Floor Plan

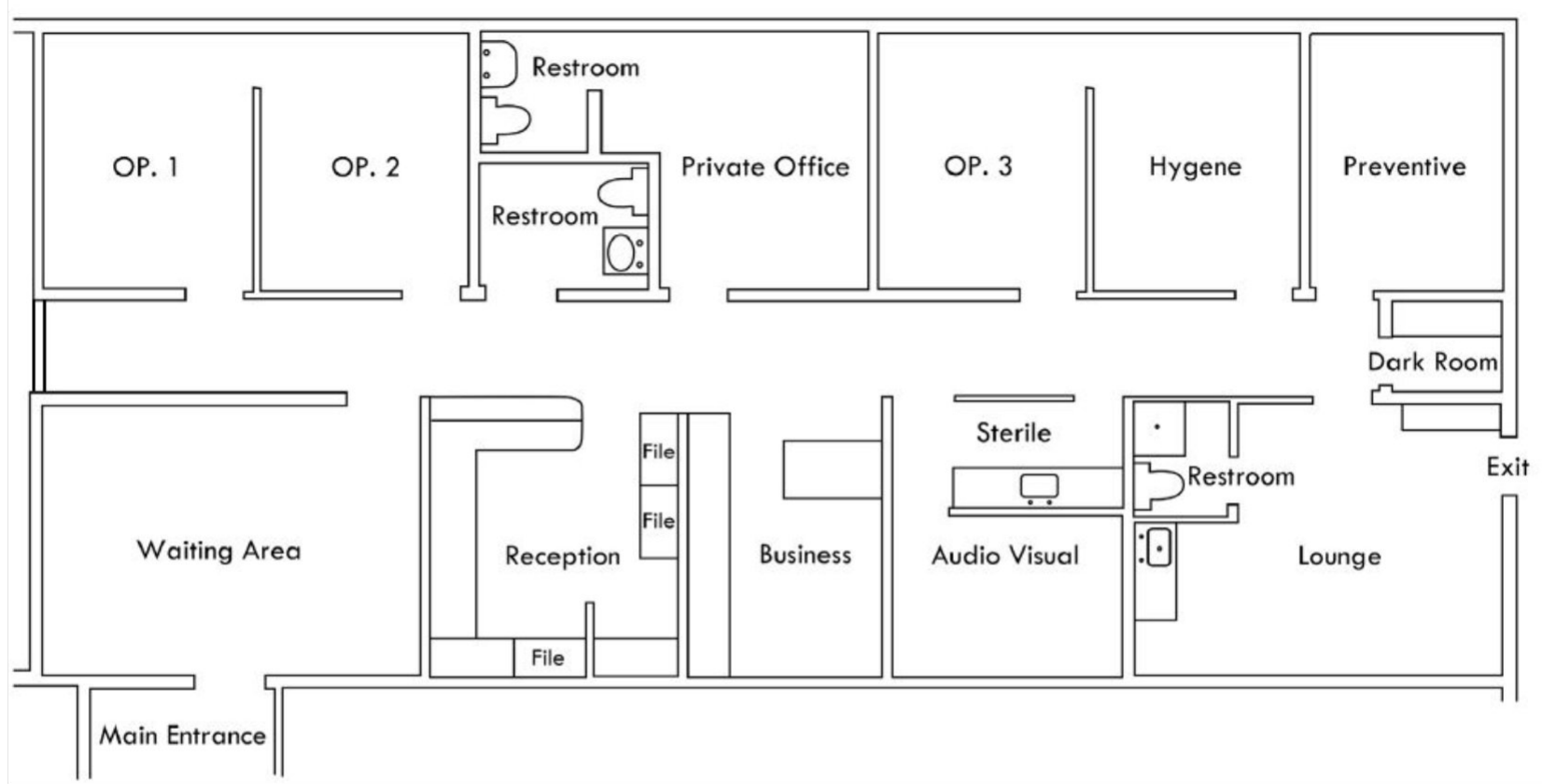

Suite 402

1,670 SF

This information is compiled from data which we believe to be correct but no liability is assumed by this company as to accuracy of such data. V1

Floor Plan

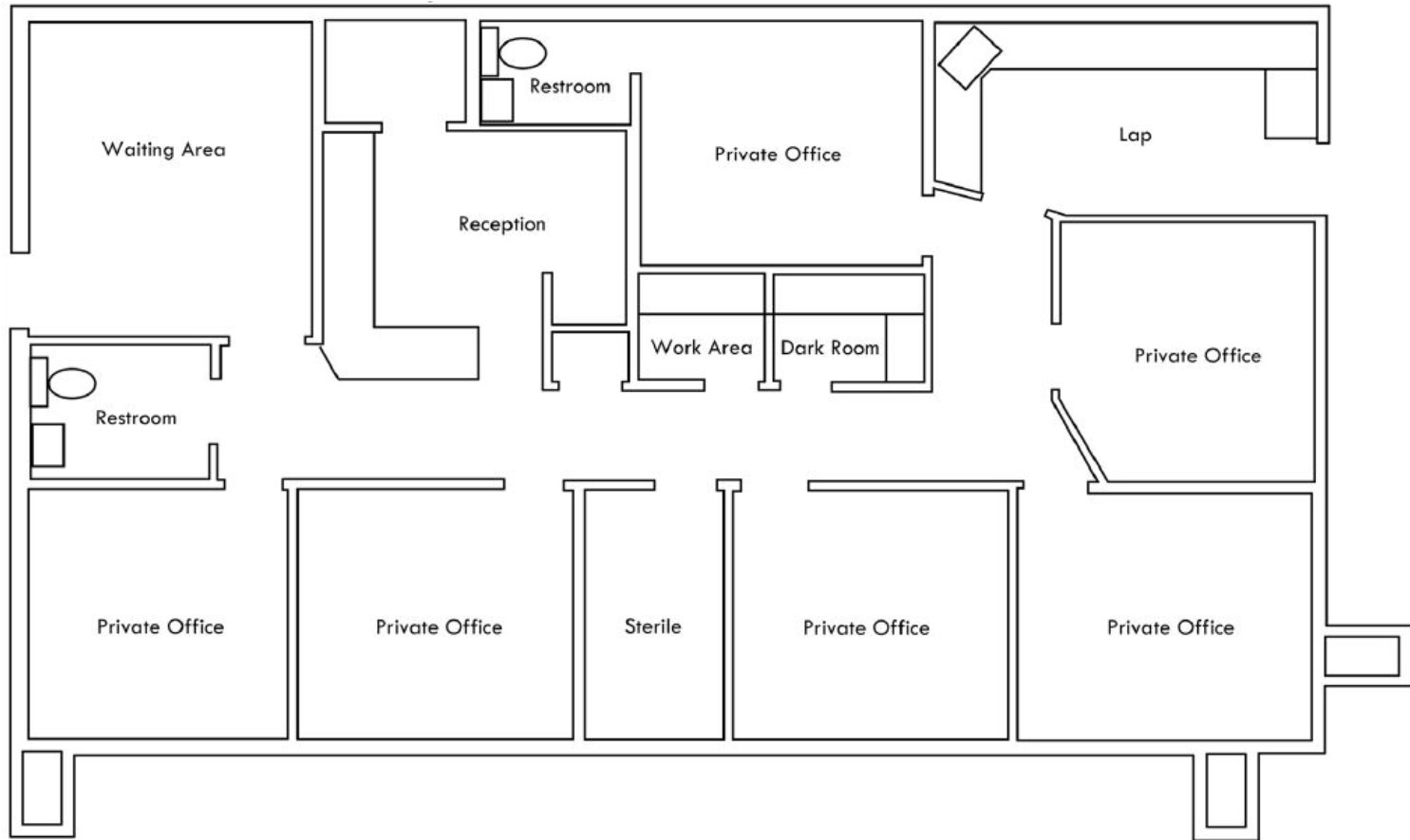

Suite 403

1,467 SF

Aerial Map

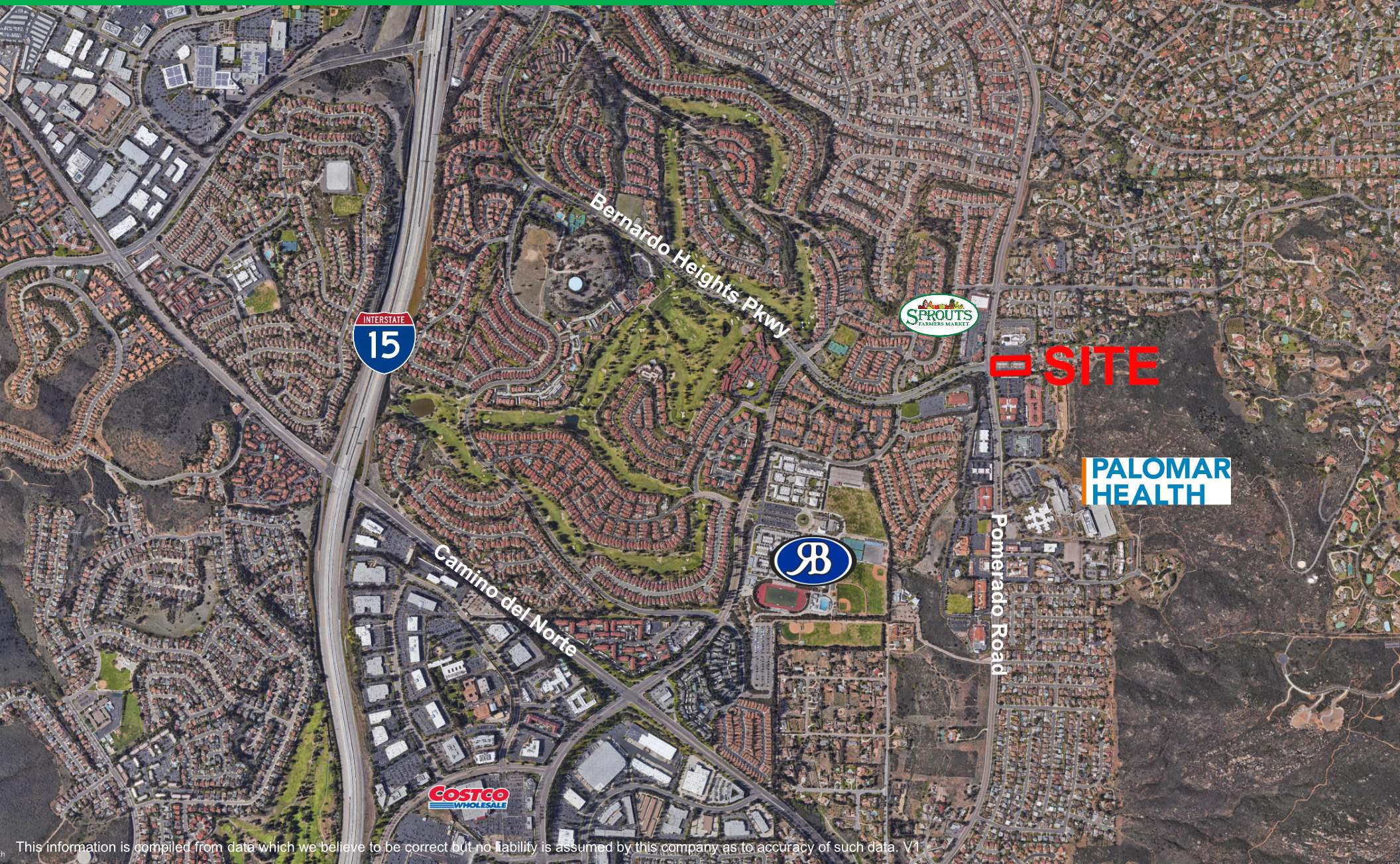

This information is compiled from data which we believe to be correct but no liability is assumed by this company as to accuracy of such data. V1

Demographics

Population	2 Mile	5 Mile	10 Mile
2021 Total Population:	41,674	176,280	512,274
2026 Population Projection:	41,938	178,953	520,229
Pop Growth 2010-2021:	0.4%	0.9%	0.9%
Median Age:	46.7	40.8	37.9
Households			
2021 Total Households:	16,505	63,547	170,535
HH Growth 2021-2026:	0.1%	0.3%	0.3%
Median Household Inc:	\$116,504	\$121,698	\$110,685
Avg Household Size:	2.5	2.7	2.9
2020 Avg HH Vehicles:	2.00	2.00	2.00
Housing			
Median Home Value:	\$758,951	\$771,782	\$751,872
Median Year Built:	1982	1985	1985



This information is compiled from data which we believe to be correct but no liability is assumed by this company as to accuracy of such data. V1